

Table of Contents

Introduction P1

Fit, Form, and Function P2

Value Added P4

Holiday House P6

Great Lakes P8

 Ensuring Scalability When Modifying Valves

 Great Lakes Air Products

 Scalability

 Why Specialty Manufacturing?

Custom Zerk P10

Vertically Integrated Manufacturing P12



Corporate headquarters for The Specialty Manufacturing Company Inc. are located just North of St. Paul, Mn. Combined with three other locations in the state, the company operates over 250,000 sq.ft. of manufacturing floor.

Introduction

“Custom Is Our Specialty.”

This has been the guiding principle behind the work of The Specialty Mfg. Co. (SMC) from the beginning. Throughout more than a century of working in the manufacturing industry, the company has created custom valves that solve problems and bring the ideas of a diverse engineering audience from concept to reality.

As essential components for a wide range of pneumatic, fluid control and custom applications, our metal and plastic valves have applied in the real-world applications you will read more about in this guide. We design and manufacture check valves, ball valves, needle valves, miniature valves and more. In addition, we serve customers from a virtually all industries. Our specialties include: agriculture, chemical dispensing, cleaning, construction equipment, dental, fire protection, food and beverage, HVAC, power generation, transportation and water - custom valve solutions for almost any fluid or gas flow application.

One of the things that sets Specialty Mfg. apart from others is its unique process for working with customer designs and product specifications. Anyone who visits our website can use our sophisticated valve specification tool, the Product Configurator, to quickly home in on desired valve features such as material, configuration, inlet/outlet, maximum operating pressure and more. The configurator then produces CAD files, 2D and 3D drawings, and product data sheets that can be viewed, downloaded or printed. The Specialty Valve Configurator is useful not only for design engineers who know exactly what they need, but also for anyone looking to browse an overview of the possibilities. It's even possible to make changes to the CAD file before sending it back to us for production – giving users even more control over getting exactly what they need.

At Specialty Mfg., we are proud of our ability to respond to customer requirements and solve the types of valve problems that others simply can't. We can create valves that are safe to use around food and beverages, as well as valves that can handle some of the most demanding media such as corrosive substances, extreme temperatures or continuous use. We are also specialists in the design and manufacture of valves under one inch in diameter.

Our support capabilities, moreover, are second to none. We share an understanding with our customers that success springs from quality products, and back up that philosophy by offering single-point-of-contact technical support from experienced project managers. We also maximize plant efficiency by basing our assembly operations on the principle of demand-driven manufacturing. This allows us to accurately produce valves to exacting specs, and quickly ship them to customers - typically within three weeks from order placement.

Please browse through the rest of this guide to learn more about The Specialty Mfg. Co., or visit our website to try out the Valve Configurator tool - and start imagining the possibilities.



**WE ARE
SPECIALISTS**

in metal and plastic
valves under one inch.



**WE
COLLABORATE**

with customers to solve the valve
problems others can't or won't.



**THE
EXACT VALVE**

you need...



**DELIVERED
ON TIME**

Fit, Form and Function

The Material Importance of Fit, Form and Function

Today's smaller and lighter automotive engines achieve greater speed than their predecessors while consuming less fuel. The simultaneous reduction of emissions and increased miles per gallon (MPG) figures testify to how truly efficient these engines have become. The downside of the more stringent performance requirements, however, results in a greater susceptibility for a buildup of deposits to occur in air induction and fuel systems, damaging the ratio between air and fuel.

One solution, created by BG Products, a supplier of aftermarket automotive products and equipment, was to assist lubrication companies and car dealerships by designing a way to clean the fuel injection and air induction systems, eliminating the deposits. The company's [BG VIA® Vehicle Injection Apparatus](#), a supply tool pressurized by shop air, uses BG cleaners to remove deposits from combustion chambers, fuel injectors and other critical fuel components. The result is restored airflow and fuel efficiency, decreased emissions and improved engine performance.

The BG VIA® works by pouring the BG cleaner into the top of the device, increasing the pressure and then running the process until the system is clean.

What BG needed for its design was an easy way to release the pressure buildup in the BG VIA. By adding a pressure relief button, the operator can easily release air pressure after the cleaning procedure.

The Material Challenge

When the design engineers at BG Products approached their engineering counterparts at Specialty Manufacturing (SMC), they requested that SMC tap into its capabilities and insert unique functionality into their device.

An SMC 410 check valve was already designed into the device, so the BG team requested that SMC create a similar design with a small push button to release the built-up pressure. The challenge, however, would be to innovate a solution that could withstand the caustic media that the valve would come in contact with during the cleaning process.

SMC went through several material possibilities for O-rings that would seal the valve and also survive the caustic environment. Finally, they settled on a custom O-ring made of Aflas®, a unique material that would not break down over time.



PN 9290-200 22 oz. (650 mL) canister

After three months of research, design and testing, SMC delivered a solution that was within the budget constraints and made from a high-quality, durable material. It has worked so well that in the seven-plus years since the solution was adopted thousands of valves have been purchased for the BG VIA supply tool.

Why Specialty Manufacturing?

In the case of BG Products, value-added engineering meant customization, based on finding an application-specific material for a challenging application. The need for customization can be prompted to meet several diverse requirements, including:

- Fluid chemistries that will come in contact with a valve
- Flow rate: the amount of air, water or other liquid that will go through the device
- Pressure requirements, which are a common factor in valve design and modification

SMC does whatever is necessary to deliver an application-specific solution for all value-added engineering projects, and refrains from saying no to reasonable or complex requests.

The willingness to customize and the expertise to do it right, represent the value-added engineering culture at SMC. This is apparent when visiting the [Specialty Manufacturing Online Configurator](#). Scroll through the vast number of options available for seals, pressure, temperature, flow and metal and plastic materials. The configurator offers a comprehensive overview of possibilities to match the most stringent specifications.

The heart of SMC’s customization capabilities is its customers, those that design a device or equipment and then ask, “What if we do this?” At that point, Specialty Manufacturing partners to innovate, create and deliver solutions that make “this” the best possible experience.

1 ACTIVATE CONFIGURATOR FROM QUICK START BUTTON ON SPECIALTYMFG.COM



CONFIGURE AND VIEW YOUR VALVE IN 3D NOW!

2 SELECT YOUR VALVE TYPE AND MATERIAL

**Find the exact valve you need now!
Try the Specialty Valve configurator.**



Your Valve Made Real

The Specialty Mfg. valve configuration app. is easy-to-use and can be found on www.specialtymfg.com

Value Added

Value-added Engineering is a Specialty Effort

Value-added engineering simply means just that. It enhances and customizes a standard solution so that it works better; offers cost, reliability and performance benefits; or uniquely solves a long-standing challenge.

Providing value-added engineering is more than lip service and empty claims. It requires that an engineering team be in place, tasked with improving project quality and employing a high level of skill, communication and collaboration that adds value at every step along the way.

Specialty Manufacturing takes standard, off-the-shelf valves and components and adds application-specific value to designs for its customers. The ability to listen, evaluate, customize, test and deliver solutions - ranging from a minor tweak to a major redesign - defines Specialty Manufacturing and its missions. Here are four examples that illustrate the types of challenges it routinely solves.



Figure 1. Specialty Manufacturing check valve solves fuel-line backflow challenges in a forklift tractor.

Fuel Line Backflow

When a major industrial equipment manufacturer experienced fuel line backflow problems on fuel lines used in fork lift tractors, a variety of standard valves were considered. Possible solutions ranged from ball check valve prototypes to a simple brass check valve, with modifications for cost and function. After collaborating with Specialty Manufacturing, the solution, created over the span of three months, modified a standard design for a precise fit for the specific application footprint. It involved the addition of a spring that regulated valve activation, custom barbed inlet and outlet ends and nickel plating, resulting in effective operation.

In this case, the customization provided a reduction in long-term costs for the successful product, as well as a reduction in warranty repairs.

Engineering for Reliable Diesel Exhaust

Reducing the size of one valve often begins a chain reaction of finding additional smaller valves to complete a system. This was the case for a global diesel equipment manufacturer. When implementing a smaller footprint for a valve on a diesel exhaust system, they needed a valve that could fit into a smaller manifold.

Specialty Manufacturing worked closely to deliver a preset and tamper-proof cartridge-style regulator that could be threaded into a manifold. While a standard design and common internal components such as spool spring and seal remain, the modification



Figure 2. Specialty Manufacturing delivered a customized check valve solution that met miniaturization requirements and contained costs.

centered on customized external elements including ends, threading and materials.

The modifications, while slight, are effective. Not only did Specialty meet size requirements, the relatively low-cost valve solution increased reliability.

Hog Watering Valve Eliminates Flow and Leakage Woes

One of the largest family-owned pork producers in the United States needed to improve the flow of water and subsequently find a valve design that could efficiently and effectively deliver water to their hogs. Addressing an inconsistent water flow through the valve was the first step to improve the valves performance. To improve water flow Specialty engineers recommended a redesign of an internal plastic nozzle that could be used with the existing valve. Prototypes were developed and tested successfully. The result was more consistent and predictable water flow.



Figure 3. A custom toggle-valve design resulting in 30 percent water consumption reduction at production facilities, as well as 18-22 percent drop across the entire system. Source: Specialty Manufacturing

The second phase, implemented after the use of the new nozzle design for a year, involved improving the overall valve design's manufacturing inconsistencies and early valve wear and tear. Specialty Manufacturing would need to engineer a solution that could eliminate leaks, last seven to 10 years and work with the existing water distribution system as well as a new, planned water system. The Specialty solution involved changes to threading, internal springs and a new toggle design. While major design customization was required, Specialty took only eight weeks, accessing its in-house engineering, machining, prototype and testing capabilities.

With an operation that spanned 44 farms and four Midwest states, the stakes were high. Specialty engineers reengineered the valve to eliminate design flaws and optimize water flow. Once implemented, the customization yielded an annual savings of millions of gallons of water and thousands of dollars in manure transfer costs.

Delivering a Unique Hydronics Valve Configuration

Often, value-added engineering is based on much more than a simple design change. For example, when a hydronics-system company required a compact check valve for a new application that delivered glycol and water at ambient temperature with a 0.25 crack pressure, the demanding requirements would have caused most valve manufacturers to simply pass on the opportunity.

While Specialty Manufacturing's 406 series compact check valve met the customer's footprint specification, it also needed a 1/4 inch male NPT(4M) outlet that could meet configuration requirements.

The resulting solution, based on substantial collaboration between Specialty and the customer, not only met performance and space requirements, but also used a poppet functionality that improved sealing properties. The long-standing customer was confident enough in Specialty's dedication and commitment that it chose not to look at competitive options. The collaboration resulted in the creation of new injection mold tooling and prototypes plus additional testing. The customer experienced improved reliability and performance advantages with the value-added design.

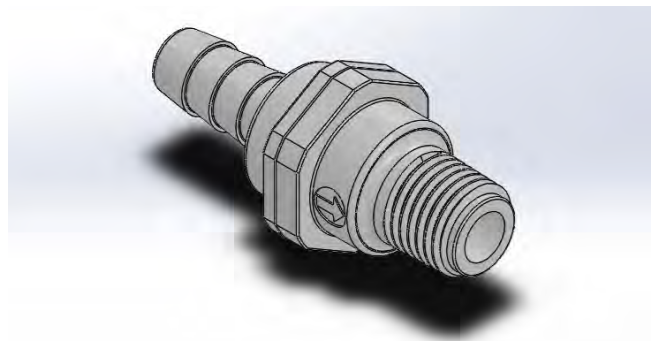

Figure 4. Specialty Manufacturing's 406 plastic check valve was modified with customized end and cracking pressure to meet application requirements. Source: Specialty Manufacturing

Adding Value Long Term

It's not surprising that Specialty Manufacturing sees a lot of repeat business from its client base over the long haul, in addition to attracting new customers. The value-added engineering skills and services yield unmistakable results, including greater overall efficiency and cohesive project collaboration and management for each and every project. Discover how the Specialty Manufacturing Co. can collaborate with you to solve the valve performance challenges in your application. To get started, visit <https://www.specialtyvmfg.com/configurator/>.

Holiday House

A Shared Philosophy Ensures Repeat Business

When Holiday House Distributing, the largest distributor of OCS, water and vending parts in North America, needed a modification to a ball valve design, there was no question that it would ask The Specialty Manufacturing Co. (SMC) to create it. Although Holiday House could have chosen to continue to perform manual assembly of the fitting, or instead farm out the assembly, experience told them that Specialty would be able to reengineer an existing part and supply all the expertise needed to do so.

The Challenge

Holiday House needed a 1/2 inch male NPT end for the Specialty Manufacturing 074-Series plastic ball valves that would not leak under pressure, while replacing two existing parts. The existing solution used by Holiday House required multiple operations and sub-assembly to arrive at the intended outcome.

According to Blackie Ouellette, Holiday House general manager, “We asked Specialty to create a ball valve that could eliminate two existing parts and be more streamlined and easier to assemble. In this case, we knew that they had the knowledge and were already creating the required fitting. Since we’ve been a long-term Specialty Manufacturing customer, we knew that they readily go out of their way — just like we do for our customers.”



Figure 1. SMC can reengineer existing ball valve designs and develop custom solutions for many valve challenges. Source: The Specialty Manufacturing Co.

“We typically look at their product catalog to see what they have that’s close and then we ask if a part can be modified,” added Ouellette. “In this case, it was to remold an end and shrink it down to a half-inch in size. When SMC knocks out a solution and sends me a sample, that sample is spot on. I’ve never had to send one back to have it redone.”

The Solution

“This one was a case of changing what we currently had, eliminating the parts and having a more cost-effective unit and have a variance that would be easier when assembling the unit,” said Ouellette. “Specialty saved us time and money because there were fewer things to put together.”

In the case of Holiday House, providing the 1/2 inch male NPT end and eliminating the cost and need for additional fittings. Specialty not only designed a new end that met requirements, it also agreed to absorb the tooling costs based on volume purchasing by Holiday House, without changing their distributor pricing.

The design was completed in 17 days from original inquiry to receipt of purchase order and a 10-week lead time for tooling and production. Not only did Holiday House receive the solution it needed, the company had a new end configuration that it could add to its catalog.

A Shared Philosophy

When you sit down and talk to the management of both companies, there's little doubt as to why Specialty Manufacturing and Holiday House Distributing do business. Bottom-line, their business philosophies are close to identical. Both share an old-world approach to business, unafraid to create and deliver exactly what the customer wants and needs.

Specialty Manufacturing has a 100-year history of value-added valve design and design for manufacturability. Given that the right valve saves both time and money when optimizing flow control performance is concerned, the company often customizes its standard offerings to deliver the exact part needed.

Ouellette explained that Holiday House has approximately 6,000 customers spanning large corporations to mom-and-pop shops, and each means as much to the company as the next one.

"We try to make sure that we take care of all of them equally and Specialty Manufacturing shares this way of doing business," said Ouellette.

Specialty Manufacturing agrees; whether it is a simple brass ball valve or mini ball valves, its customers relate what they are looking for and the company will devise and manufacture a valve that's exactly right for the function it requires.

This experience with The Specialty Manufacturing Co. was not unique. "I've not run across a challenge that the company didn't easily solve," he said. "They provide six to eight different types of ball valves in the black color that we use, and each is built the way that we ask for it. We have good communication with them, and we're both on the same page. I take care of my customers the way that Specialty Manufacturing takes care of me. For us, it's not just a trend, it's a way of life."

Figure 1. Moving from 0.5 in. to 0.75 in. required collaboration, design, test and verification to ensure that the valve provided the required air flow, without lowering the performance Great Lakes needed in previous versions of regenerative compressed air dryers. Source: Specialty Manufacturing Co.



Great Lakes

Ensuring Scalability When Modifying Valves

When products are modified or newly designed, components must be found that operate with the underlying evolving requirements. For example, when Great Lakes Air Products decided to launch a new line of regenerative compressed air dryers, it wanted to substantially increase the air flow delivered. It made perfect sense for Great Lakes to call on Specialty Manufacturing Company, a provider of brass check and ball valves for earlier iterations of similar equipment at Great Lakes. The new design moved the brass check and ball valve 50 percent larger from its current size of 0.5 in. That process was hardly a first, however. Previously, the 0.5 in. valve had replaced the 0.25 in. valves on similar equipment and Specialty Manufacturing Co. had designed both.

Not only did Great Lakes want to increase air flow for its new air dryers, it was critical that the products maintain the high level of performance achieved in the earlier designs. Now, it was again time to take the size of the brass check valve reliably all the way up to 0.75 in., without any performance penalty.

Great Lakes Air Products

Great Lakes is a forward-thinking company that plans and collaborates well with its vendors. A long-term customer of Specialty Manufacturing Co., Great Lakes worked closely with Specialty Engineers to collaborate on the design, prototype, test and verification of the larger valves. The launch of a new line by Great Lakes involved four regenerative dryers:

- GMR Heatless Regenerative Compressed Air Dryer, a pressure swing adsorption (PSA) dryer with a full 10-minute NEMA cycle, delivering a reliable -40° F pressure dew point in a compact, wall-mountable design.
- GPS Heatless Regenerative Compressed Air Dryer, an industrial-grade PSA air dryer that delivers a reliable -40° F pressure dew point, with optional designs for -100° F, optimized for capacities of 25-3,000 standard cubic feet per minute (SCFM).
- GEH External Heated Regenerative Compressed Air Dryers use a low-watt density Incoloy sheath heater to increase efficiency and reduce required purge air to 7 percent or less, with the standard series designed for 100 to 25,000 SCFM capacities.

- GS Blower Purge Regenerative Compressed Air Dryer uses an atmospheric blower and low-watt density Incoloy sheath heater to increase efficiency and eliminate required purge air in the blower-only mode.

Scalability

Scalability isn't just the ability to make something smaller or larger. It involves geometric and non-geometric aspects of a 3D model to arrive at feasibility, material selection, production, processes and cost. Using an engineering approach to design, test and verify the results is imperative. A deep understanding of scalability, manufacturability and virtually all aspects of design ensures that errors and design iterations are minimal. Given that most valves used in such equipment are designed to meet ISO standards, any modification must ensure that standards continue to be met.

Critical to Great Lakes Air Products redesign is scalability. Specialty Manufacturing Co. worked closely with Great Lakes Air Products for project success. Through collaboration, Specialty Manufacturing Co. and Great Lakes innovated a valve solution that scaled perfectly, meeting all design criteria for the new air dryer.

Why Specialty Manufacturing?

While it seems obvious that when a customer contacts a supplier requesting custom modifications, there would at least be an attempt to dig deeper into whether or not the request is viable. In a commodity-product industry, such as valves, this is seldom true. Commodity manufacturers, selling from catalogs or online, typically respond to requests for modification with an emphatic, "No, we don't offer that," and that's where it ends.

Would it be easier to just sell standard products out of a catalog? Probably, yes. Specialty Manufacturing, however, loves a challenge. For more than a century, the company has provided high-quality standard and custom products. The ability to customize and the expertise to deliver specifications to reflect their strong customer-focused engineering culture and the attention to scalability are critical to successful custom design. The company eagerly takes on projects that other companies won't attempt.

Specialty Manufacturing Co. revels in the collaboration process, improving design function and the manufacturability of valves. The Specialty Manufacturing Co. website is uniquely equipped to help design engineers select the right valve for their application. The [Specialty Valves configuration tool](#), for example, walks the user through selecting a valve and designing it in 3D.



Figure 2. The GEH External Heated Regenerative Compressed Air Dryer by Great Lakes, one of four dryers in the new line that required a larger brass check valve to increase air flow. Source: Great Lakes Air Products

The configurator allows users to navigate valve attribute considerations to find the ideal solution for the application. Simply select from valve types and allow the configurator to guide the selection process and display results. Users can view and compare search results, compare CAD models and detailed product drawings, then download and import exactly what is needed. Additional assistance is always available.

Engineering and vertically integrated manufacturing expertise ensures the delivery of the right, high-quality and application-specific solution perfectly scaled to your needs. [Visit Specialty Manufacturing Company](#) to explore how its willingness to say, "Yes!" can help with your next product design or modification.

Custom Zerk

Custom Coupler simplifies the lubrication and maintenance for track tensioning systems.

Time is money when managing routine maintenance and lubrication of drive tracks on excavating equipment. Efficiency of the filling and flushing of the lubricants that optimize equipment uptime is vital. To make this work, the successful design required a reliable and durable mechanism to inject grease into the system and then reverse pressure to allow the grease to be flushed from the system and recharged with fresh grease.

A globally recognized manufacturer of excavating machinery developed a single zerk hydraulic system designed to deliver and bleed grease used to set/adjust track tension on their equipment. Engineers at the Specialty Manufacturing Co. were engaged to examine the hydraulic zerk design for its overall function and manufacturability. After design review and testing, Specialty engineers responded with recommendations to improve durability and ensure leak-free performance.

After thorough review, two concerns with the original design were identified.

1. The ball seal in the zerk design was suspect and had the potential to leak which presented a possible environmental hazard, as well as reliability concerns.
2. The coupling end of the zerk was too soft and was susceptible to damage and accelerated wear.

To address these issues and optimize both function and manufacturability, Specialty Engineers offered two important recommendations.

Specialty Mfg. customized grease zerk accommodates injection and flushing of grease for excavator track adjustment.



Custom Grease Zerk

Recommendation #1.

Set an acceptable leakage rate and adopt design and control features to achieve it. A modified steel check valve (ball and seat) to seal the grease reservoir and maintain pressure was recommended to hydraulically activate adjustment of track tension systems. Engineers recommended a **customized ductile base metal body** for the fitting with an integrated ball that when put under pressure seals against the zerk body to create a seal that holds up through routine use and lubricant cycles.

Recommendation #2.

To address the softness in the metal on the top of the zerk body a dual hardening process was identified that would **harden only the top** and allow for a consistent connection with grease delivery tools and maintain the required ductility to satisfy recommendation 1.

“We are confident that our recommendations improve the reliability and performance of this component under the most rugged use conditions and cost expectations.” Commented Nick Goenner, Specialty Hydraulic Engineering Manager.

Result- The design recommendations were implemented and prototype parts were produced that were tested and approved by the OEM. Today this single zerk system has been adopted on the company’s equipment and continues to exceed expectations for performance, durability and cost.

This problem solution scenario is a hallmark of The Specialty Mfg. Company. The company takes pride in adding value to customer designs and designing-in improved manufacturability and performance within defined cost objectives.

The Specialty Mfg. Company’s, engineering, testing, assembly and customer service is all housed on one campus in near St. Paul, Mn.

Vertically Integrated Manufacturing

Specialty Manufacturing's design innovation and problem-solving expertise is supported by the company's fast, reliable delivery. We bring value-added engineering, precision metal machining, plastic injection molding, stamping and grinding, and assembly operations all under one roof.

Turning ideas into efficient solutions is the result of collaboration and partnership with our customers. We specialize in adding value to fluid transfer system designs to optimize function and manufacturability.

We have the right machines and experience to economically produce parts to precise specifications—from simple to complex in low volume to large production runs. Multi-Axis CNC, Swiss CNC, MultiSpindle Acme, Hydromat Rotary Transfer, Makino and Haas Vertical Mills.

A full-service injection and insert injection molding partner with the shortest lead times in the business. Full range of precision injection molding with equipment from 2oz/80-ton to 80oz/500-ton capacity

We produce custom cutting blades for the tape, paper and plastics industries. Proprietary crush grinding techniques yield one of the longest edge sharpness durations in the industry.

Press capability from 10 tons (for Miniature Stampings) to 110 tons. Parts from .003" up to .130" thick. Specialties include medium/high volume precision stampings

We streamline supply chain management by producing fully assembled, ready to install components that meet your specifications. Using the latest equipment and methods, we often coordinate a variety of outside services that when combined with machined, stamped and molded components completes the scope of our manufacturing capabilities.

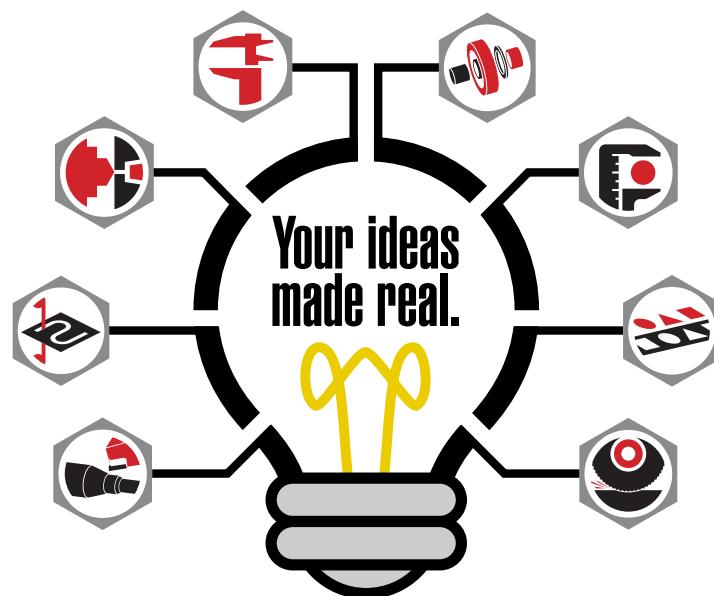

**Metal Machining • Wire EDM • Plastic Injection Molding • Engineering
Assembly • Quality Control • Stamping • Grinding**

The Specialty Mfg. Co. (SMC) is organized into six vertically integrated divisions. Primary product lines are metal and plastic valves, Quick disconnect couplers and dental components.

Our Valve division manufactures a wide variety of ball, check and needle valves. Since 1900, the company has served a broad range of industries including automotive, water purification, medical, beverage, and chemical dispensing. SafeWay is a leading supplier of quick action hydraulic couplings for the industrial, agricultural and mobile equipment industries. The Specialty Dental division manufactures and sells small pneumatic valves, manifolds, and custom injection molded parts for the dental industry. Specialty Integrated Services offers decades of contract manufacturing experience in precision machining, metal stamping and injection molding. The company's Rola-Chem and Paradise brands produce peristaltic pumps, controllers, flow meters and other products for the commercial and residential pool/spa industry. New Ulm Precision Tool is a custom fixtures and tools manufacturer.

<https://www.specialtymfg.com/>

Contact Us

<https://www.specialtymfg.com/contact-us/>

Email: info@specialtymfg.com

5858 Centerville Rd. St. Paul, MN 55127 USA

Phone: (651) 653-0599| Fax: (651) 653-0989

THE SPECIALTY MFG. CO.
Custom Is Our Specialty